

**User's Manual / Installation Instructions****Two Stage R-410A Split System**

Premium Model Shown

**IMPORTANT**

Please read this information thoroughly and become familiar with the capabilities and use of your appliance before attempting to operate or maintain this unit. Keep this literature where you have easy access to it in the future. If a problem occurs, check the instructions and follow recommendations given. If these suggestions don't eliminate your problem, call your servicing contractor .

These instructions are primarily intended to assist qualified individuals experienced in the proper installation of this appliance. Some local codes require licensed installation/service personnel for this type of equipment. Please read all instructions carefully before starting the installation.

**DO NOT DESTROY. PLEASE READ CAREFULLY AND  
KEEP IN A SAFE PLACE FOR FUTURE REFERENCE.**



## USER INFORMATION

<b>Safety Information</b> .....	4	Oper. the Indoor Blower Continuously .....	5
<b>About the Air Conditioner</b> .....	4	Shutting the AC Off.....	5
What are the Benefits of a Split System?.....	4	<b>Warranty Information</b> .....	5
What are the Benefits of Two - Stage Variable Speed Cooling? .....	4	<b>System Maintenance</b> .....	5
<b>Operating Instructions</b> .....	4	Regular Cleaning.....	5
Cooling Operation.....	4	Before You Call a Technician .....	5
Heating Operation .....	4	<b>Troubleshooting</b> .....	5

## INSTALLER INFORMATION

<b>Safety Information</b> .....	6	High Pressure Switch .....	9
Pressures Within the System .....	6	Comfort Alert™ Diagnostic Module.....	10
Labels, Tags, and Precautions.....	6	24VAC Power Wiring .....	10
Brazing Operations.....	6	Thermostat Demand Wiring .....	10
<b>General Information</b> .....	7	Interpreting the Diagnostic LED's.....	10
Outdoor Unit Selection .....	7	LED Description .....	10
Liquid and Suction Lines .....	7	Two - Speed Outdoor Fan Motor .....	11
Field Connections for Electrical Power Supply.....	7	Optional Equipment.....	11
<b>Site Preparation</b> .....	7	Grounding.....	11
Unpacking the Equipment .....	7	<b>Startup &amp; Adjustments</b> .....	11
Inspect for Damage .....	7	Pre - Start Checklist .....	11
Preferred Location of the Outdoor Unit.....	7	Thermostat .....	11
Facility Prerequisites .....	7	Outdoor Unit .....	11
Minimum Circuit Ampacity .....	7	<b>Functional Checkout</b> .....	11
Maximum Fuse / Circuit Breaker Size .....	7	Cooling .....	11
<b>Installing the Indoor Unit</b> .....	7	Heating .....	11
<b>Installing the Outdoor Unit</b> .....	7	Indoor Blower .....	11
Slab Mount .....	7	Short Cycle Protection.....	12
Cantilever Mount .....	7	Optional Equipment.....	12
Roof Mount .....	8	<b>Adjustment of Refrigerant Charge</b> .....	12
<b>Connecting Refrigerant Tubing Between the Indoor and Outdoor Unit</b> .....	8	Charging R-410A Unit in AC Mode.....	13
General Information.....	8	<b>Cooling Charging Charts</b> .....	13
Filter Drier Installation .....	8	<b>Troubleshooting Tables</b> .....	16
Optional Equipment.....	8		
<b>Electrical Connections</b> .....	8		
Pre - Electrical Checklist.....	8		
Wiring Diagram / Schematic.....	8		
Line Voltage .....	8		
Outdoor Unit Connections .....	9		
Control Circuit Wiring.....	9		
Thermostat Connections .....	9		
Low Pressure Switch .....	9		

# USER INFORMATION

## SAFETY INFORMATION

**IMPORTANT:** Safety markings are used frequently throughout this manual to designate a degree or level of seriousness and should not be ignored. **WARNING** indicates a potentially hazardous situation that if not avoided, could result in personal injury or death. **CAUTION** indicates a potentially hazardous situation that if not avoided, may result in minor or moderate injury or property damage.

## ABOUT THE AIR CONDITIONER

Your 16 SEER air conditioner has been carefully designed and engineered to give you outstanding energy efficiency and years of trouble-free operation. This appliance uses only proven components, such as the Ultra-tech Copeland® scroll compressor, a leaders choice for efficiency, durability, and longevity.

### What are the benefits of a split system?

Split systems are designed to work efficiently for cooling in any climate. Split systems have two main components: the outdoor section (air conditioner or heat pump) and the indoor section (matched air handler or coil). These two sections work together to provide top performance, maximum efficiency, and comfort.

### What are the benefits of two stage; variable speed cooling?

- Two stage cooling products maintain a more consistent comfort level throughout your home. The AC always starts in first stage and attempts to meet the cooling demand. When the temperature rises, the air conditioner or heat pump automatically adjusts itself and enters the second stage to meet increased cooling demands.
- A two stage, variable-speed unit runs for longer cycles and will remove up to six times more moisture than a conventional unit. The result is a more comfortable environment even at a higher thermostat setting.
- Since the fan operates slower during the low stage cooling demand, the fan motor produces less fan noise. The variable speed motor ramps up slowly, eliminating uncomfortable temperature swings. Since the unit runs at the stage needed based off demand, you never pay for energy that is not needed.

## OPERATING INSTRUCTIONS

Please refer to the thermostat manufacturer's User Manual for detailed programming instructions.

For this type of equipment to function as intended, a two stage cooling / heating thermostat is required.

### Cooling Operation

1. Set the thermostat's system mode to COOL or AUTO and change the fan mode to AUTO. See Figure 1
2. Set the temperature selector to the desired temperature level. The outdoor fan, compressor, and blower motor will all cycle on and off to maintain the indoor temperature at the desired cooling level.

**NOTE:** If the temperature level is re-adjusted, or the system mode is reset, the fan and compressor in the outdoor unit may not start immediately. A protective timer circuit holds the compressor and the outdoor fan off for approximately three minutes following a previous operation or the interruption of the main electrical power.

### Heating Operation

1. Set the thermostat's system mode to HEAT or AUTO and change the fan mode to AUTO. See Figure 1.
2. Set the temperature selector to the desired temperature level. The compressor, outdoor fan, and blower motor will cycle on and off to maintain the indoor temperature at the desired heating level.

**NOTE:** If the temperature level is re-adjusted, or the system mode is reset, the fan and compressor in the outdoor unit may not start immediately. A protective timer circuit holds the compressor and the outdoor fan off for approximately three minutes following a previous operation or the interruption of the main electrical power.

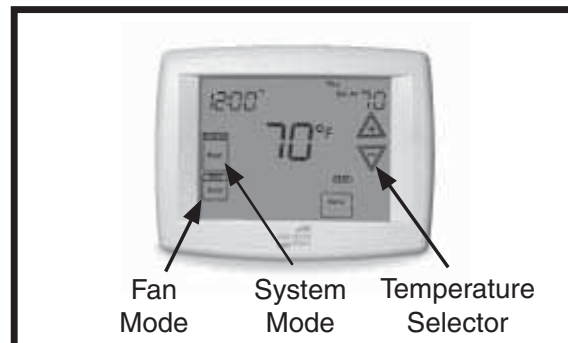

Figure 1. Digital Thermostat

## USER INFORMATION

### Operating the Indoor Blower Continuously

The continuous indoor blower operation is typically used to circulate the indoor air to equalize a temperature unbalance due to a sun load, cooking, or fireplace operation.

Set the thermostat fan mode to ON (Figure 1). The indoor blower starts immediately, and will run continually until the fan mode is reset to AUTO.

The continuous indoor blower operation can be obtained with the thermostat system mode set in any position, including OFF.

### Shutting the Air Conditioner Off

Change the thermostat's system mode to OFF and the fan mode to AUTO (See Figure 1).

**NOTE:** The system will not operate, regardless of the temperature selector setting.

### WARRANTY INFORMATION

A warranty certificate with full details is included with the air conditioner. Carefully review these responsibilities with your dealer or service company. The manufacturer will not be responsible for any costs found necessary to correct problems due to improper setup, improper installation, adjustments, improper operating procedure on the part of the user, etc. Some specific examples of service calls which are not included in the limited warranty are:

1. Correcting wiring problems in the electrical circuit supplying the air conditioner.
2. Resetting circuit breakers or other switches.
3. Adjusting or calibrating of thermostat.

### SYSTEM MAINTENANCE



## CAUTION:

**Shut off all electrical power to the unit before performing any maintenance or service on the system. Failure to comply may result in personal injury or death.**

Proper maintenance is most important to achieve the best performance from the appliance and should be performed by a qualified service technician at least once a year. Follow the maintenance schedule and the instructions below for years of safe, trouble free operation.

### Regular Cleaning

- Clean or replace the indoor air filter at the start of each heating and cooling season, and when an accumulation of dust and dirt is visible on the air filter.
- Remove any leaves and grass clippings from the coil in the outdoor unit, being careful not to damage the aluminum fins.
- Check for obstructions, such as twigs, sticks, etc.

### TROUBLESHOOTING

If the AC fails to operate, check the following:

- The thermostat is properly set. See Cooling Operation for air conditioning or Heating Operation for furnace or air handler (page 3).
- The unit disconnect fuses are in good condition and the electrical power to the unit is turned on.

## INSTALLER INFORMATION

### SAFETY INFORMATION

**IMPORTANT:** Safety markings are used frequently throughout this manual to designate a degree or level of seriousness and should not be ignored. **WARNING** indicates a potentially hazardous situation that if not avoided, could result in personal injury or death. **CAUTION** indicates a potentially hazardous situation that if not avoided, may result in minor or moderate injury or property damage.

---

### **WARNING:**

---

**Improper installation, service, adjustment, or maintenance may cause explosion, fire, electrical shock or other hazardous conditions which may result in personal injury or property damage. Unless otherwise noted in these instructions, only factory authorized kits or accessories may be used with this product.**

---

---

### **WARNING:**

---

**These units are fully charged with R-410A refrigerant and ready for installation. When a system is installed according to these instructions, no refrigerant charging is required. If repairs make it necessary for evacuation and charging, it should only be attempted by qualified, trained personnel thoroughly familiar with this equipment. Some local codes require licensed installation service personnel to service this type of equipment. Under no circumstances should the homeowner attempt to install and/or service this equipment. Failure to comply with this warning could result in equipment damage, personal injury, or death.**

---

---

### **WARNING:**

---

**The safety information listed below must be followed during the installation, service, and operation of this unit. Unqualified individuals should not attempt to interpret these instructions or install this equipment. Failure to follow safety recommendations could result in possible damage to the equipment, serious personal injury or death.**

---

- The installer must comply with all local codes and regulations which govern the installation of this type of equipment. Local codes and regulations take precedence over any recommendations contained in these instructions. Consult local building codes and the National Electrical Code (ANSI CI) for special installation requirements.
- This equipment contains liquid and gaseous refrigerant under high pressure. Installation or servicing should only be performed by qualified trained personnel thoroughly familiar with this type equipment.
- All electrical wiring must be completed in accordance with local, state and national codes and regulations and with the National Electric Code (ANSI/NFPA 70) or in Canada the Canadian Electric Code Part 1 CSA C.22.1.
- Installation of equipment may require brazing operations. Installer must comply with safety codes and wear appropriate safety equipment (safety glasses, work gloves, fire extinguisher, etc.) when performing brazing operations.
- Install this unit only in a location and position as specified on page 6. This unit is designed only for outdoor installations and should be located with consideration of minimizing the length of the supply and return ducts. Consideration should also be given to the accessibility of fuel, electric power, service access, noise, and shade.
- Follow all precautions in the literature, on tags, and on labels provided with the equipment. Read and thoroughly understand the instructions provided with the equipment prior to performing the installation and operational checkout of the equipment..



## GENERAL INFORMATION

Split System units are designed for use with a wide variety of fossil fuel furnaces, electric furnaces, air handlers, and evaporator coil combinations equipped with variable speed blowers.

This unit has been designed and tested for capacity and efficiency in accordance with A.R.I. Standards. This unit will provide many years of safe and dependable comfort, providing it is properly installed and maintained. With regular maintenance, this unit will operate satisfactorily year after year. Abuse, improper use, and/or improper maintenance can shorten the life of the appliance and create unsafe hazards.

To achieve optimum performance and minimize equipment failure, it is recommended that periodic maintenance be performed on this unit. The ability to properly perform maintenance on this equipment requires certain mechanical skills and tools.

Please consult your dealer for maintenance information and availability of maintenance contracts. Please read all instructions before installing the unit.

### Outdoor Unit Selection

Each outdoor unit is shipped with a refrigerant charge adequate to operate the outdoor section with an indoor matching coil or air handler. These units include the proper amount of refrigerant for an additional 15 ft. of refrigerant lines the same size as the valve fittings.

**NOTE: DO NOT USE ANY PORTION OF THE CHARGE FOR PURGING OR LEAK TESTING.**

Matching coils and air handlers may be shipped with a small holding charge to pressurize them to keep out contaminants. To release the pressure, read the indoor section installation instructions carefully.

### Liquid and Suction Lines

Refrigerant grade copper tubing should be used when installing the system. Refrigerant suction line tubing should be fully insulated.

### Field Connections for Electrical Power Supply

All wiring must comply with current provisions of the "National Electrical Code" (ANSI/NFPA 70) and with applicable local codes having jurisdiction. The minimum size of electrical conductors and circuit protection must be in compliance with information listed on the outdoor unit data label.

## SITE PREPARATION

### Unpacking the Equipment

Remove the shipping carton and User's Manual from the equipment. Take care not to damage the tubing connections when removing the carton.

### Inspect for Damage

Inspect the equipment for damage prior to installing the equipment at the job site. Verify coil fins are straight. If necessary, comb fins to remove flattened or bent fins.

### Preferred Location of the Outdoor Unit

Survey the job site to determine the best location for mounting the outdoor unit. Overhead obstructions, poorly ventilated areas, and areas subject to accumulation of debris should be avoided. The outdoor unit should be installed no closer than 18 inches from the outside walls of the facility and in an area free from overhead obstructions to ensure unrestricted airflow through the outdoor unit.

### Facility Prerequisites

Electrical power supplied to the unit must be adequate for proper operation of the equipment. The system must be wired and provided with circuit protection in accordance with local building codes.

### Minimum Circuit Ampacity

Electrical wiring to the equipment must be compatible and in compliance with the minimum circuit ampacity listed on the outdoor unit data label.

### Maximum Fuse / Circuit Breaker Size

Circuit protection for the outdoor unit must be compatible with the maximum fuse/circuit breaker size listed on the outdoor unit data label.

## INSTALLING THE INDOOR UNIT

The indoor unit (air handler, furnace, etc.) should be installed prior to the routing of refrigerant piping. Consult the Installation Instructions of the indoor unit for installation details.

## INSTALLING THE OUTDOOR UNIT

### Slab Mount

The site selected for a slab mount installation requires a stable foundation and not subject to erosion. The slab should be level and anchored (if necessary) prior to installation on the slab.

### Cantilever Mount

The cantilever mount should be designed with adequate safety factor to support the weight of the equipment, and for loads subjected to the mount during operation. Installed equipment should be adequately secured to the cantilever mount and levelled prior to operation of the equipment.

## Roof Mount

---



### **WARNING:**

---

**To avoid the risk of property damage, personal injury, or death, it is the installer's responsibility to ensure that whatever means are used to move or lift the unit are safe and adequate:**

**Keep the unit in an upright position at all times.**

---

The method of mounting should be designed so as not to overload roof structures or transmit noise to the interior of the structure. Refrigerant and electrical lines should be routed through suitably waterproofed openings to prevent water leaking into the structure.

### **CONNECTING REFRIGERANT TUBING BETWEEN THE INDOOR & OUTDOOR UNIT**

---



### **CAUTION:**

---

**This system uses R-410A refrigerant with POE oil. When servicing, cover or seal openings to minimize the exposure of the refrigerant system to air to prevent accumulation of moisture and other contaminants.**

---

#### **General Information**

After outdoor and indoor unit placement has been determined, route refrigerant tubing between the equipment in accordance with sound installation practices.

- When connecting refrigerant linesets together, it is recommended that dry nitrogen be flowing through the joints during brazing. This will prevent internal oxidation and scaling from occurring.
- Refrigerant tubing should be routed in a manner that minimizes the length of tubing and the number of bends in the tubing.
- Refrigerant tubing should be supported in a manner that the tubing will not vibrate or abrade during system operation.
- Tubing should be kept clean of foreign debris during installation.
- Every effort should be made by the installer to ensure that the field installed refrigerant containing components of the system have been installed in accordance with these instructions and sound installation practices to insure reliable system operation and longevity.

- The maximum recommended interconnecting refrigerant line length is 75 feet, and the vertical elevation difference between the indoor and outdoor sections should not exceed 20 feet.
- If precise forming of refrigerant lines is required, a copper tubing bender is recommended. Avoid sharp bends and contact of the refrigerant lines with metal surfaces.

#### **Filter Drier Installation**

A filter dryer is provided with the unit and must be installed in the liquid line of the system. If the installation replaces a system with a filter dryer already present in the liquid line, the filter dryer must be replaced with the one supplied with the unit. The filter dryer must be installed in strict accordance with the manufacturer's installation instructions.

#### **Optional Equipment**

Optional equipment such as liquid line solenoid valves, twinning kit, low ambient, etc., should be installed in strict accordance with the manufacturer's installation instructions.

### **ELECTRICAL CONNECTIONS**

---



### **WARNING:**

---

**Shut off all electrical power to the unit before performing any maintenance or service on the system. Failure to comply may result in personal injury or death.**

---

#### **Pre-Electrical Checklist**

- ✓ Verify that the voltage, frequency and phase of the supply source are the same as those specified on the unit rating plate.
- ✓ Verify that the service provided by the utility is sufficient to handle the additional load imposed by this equipment.
- ✓ For minimum circuit ampacity and maximum overcurrent protection, see unit rating plate.

#### **Wiring Diagram / Schematic**

A wiring diagram/schematic is located on the inside cover of the electrical box of the outdoor unit. The installer should become familiar with the wiring diagram/schematic before making any electrical connections to the outdoor unit.

#### **Line Voltage**

- Electrical power wiring must comply with the current provisions of the NEC (ANSI/NFPA 70) and with applicable local codes having jurisdiction.
- Provide power supply for the unit in accordance with the unit wiring diagram, and the unit rating plate.



- Connect the line-voltage leads to the terminals on the contactor inside the control compartment.
- Use only copper wire for the line voltage power supply to this unit (Table 1). Use proper code agency listed conduit and a conduit connector for connecting the supply wires to the unit. Use of rain tight conduit is recommended.
- See the unit wiring label for proper high and low voltage wiring. Make all electrical connections in accordance with all applicable codes and ordinances.
- Use a separate branch electrical circuit for this unit. A means of electrical disconnect must be located within sight of and readily accessible to the unit. This switch shall be capable of electrically de-energizing the outdoor unit.
- Overcurrent protection must be provided at the branch circuit distribution panel and sized as shown on the unit rating label and according to applicable local codes.

### Outdoor Unit Connections

The outdoor unit requires both power and control circuit electrical connections. Refer to the unit wiring diagram / schematic for identification and location of outdoor unit field wiring interfaces.

### Control Circuit Wiring

The outdoor unit is designed to operate from a 24 VAC Class II control circuit. The control circuit wiring must comply with the current provisions of the NEC (ANSI/NFPA 70) and with applicable local codes having jurisdiction.

### Thermostat Connections

Thermostat connections should be made in accordance with the instructions supplied with the thermostat, and with the instructions supplied with the indoor equipment. See Table 2 for proper wire gauge and their recommended lengths for typical thermostat connections. A typical residential installation with an air conditioner, thermostat, and air handler is shown in Figure 2.

### Low-Pressure Switch

A low-pressure switch is factory installed and located internally on the suction line of the outdoor unit. The switch is designed to protect the compressor from a loss of charge by interrupting the thermostat inputs to the unit.

If the suction pressure falls below 5 psig, the switch will open and de-energize the outdoor unit. The switch will close again when the suction pressure increases above 20 psig. **NOTE:** When the switch opens and then closes, there is a 5 minute short cycling delay before the outdoor unit will energize. Under normal conditions the switch is closed.

COPPER WIRE SIZE — AWG (1% Voltage Drop)				
Supply Wire Length-Feet				Supply Circuit Ampacity
200	150	100	50	
6	8	10	14	15
4	6	8	12	20
4	6	8	10	25
4	4	6	10	30
3	4	6	8	35
3	4	6	8	40
2	3	4	6	45
2	3	4	6	50
2	3	4	6	55
1	2	3	4	60

Wire Size based on N.E.C. for 60° type copper conductors.

**Table 1. Copper Wire Size**

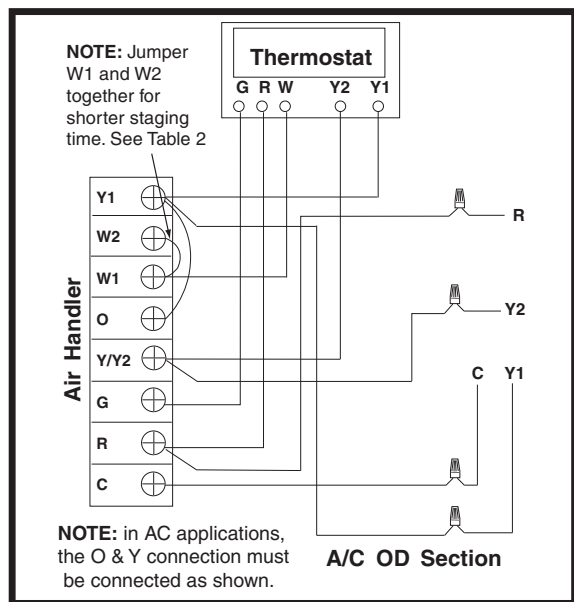

**Figure 2. Typical 2-Stage Air Conditioner with Variable Speed Air Handler**

Thermostat Wire Gauge	Recommended T' STAT Wire Length (Unit to T' STAT)	
	2-Wire (Heating)	5-Wire (Heating/Cooling)
24	55	25
22	90	45
20	140	70
18	225	110

**Table 2. Thermostat Wire Gauge**

### High-Pressure Switch

A high-pressure switch is factory installed and located internally on the compressor discharge line of the outdoor unit. If the discharge pressure rises above 650 psig, the switch will open and de-energize the outdoor unit. The switch will close again after the discharge pressure decreases to 460 psig. **NOTE:** When the switch opens and then closes, there will be a 3 minute short cycling delay before the outdoor unit will energize. Under normal conditions the switch is closed.

## Comfort Alert™ Diagnostics Module

The Comfort Alert™ diagnostics module is a breakthrough innovation for troubleshooting air conditioning system failures. The module installs easily in the electrical box of the outdoor unit near the compressor contactor. By monitoring and analyzing data from the Copeland scroll compressor and the thermostat demand, the module can accurately detect the cause of electrical and system related failures without any sensors. A flashing LED indicator communicates the ALERT code and a diagnostic key is also imprinted on the side of the module to quickly direct the technician to the root cause of a problem. See Figure 3.

**NOTE:** This Comfort Alert™ module does not provide safety protection! This module is a monitoring device and cannot control or shut down other devices.

### 24 VAC Power Wiring

The Comfort Alert™ module requires a constant nominal 24 VAC power supply. The module cannot be powered by the **C** terminal on a defrost board or other control board without experiencing nuisance alerts. **NOTE:** The wiring to the module's **R** & **C** terminals must be routed directly from the indoor unit or thermostat.

If the constant 24 VAC (**R** wire) is not present in the outdoor unit, use one of the spare wires in the thermostat cable to bring power to the module. Connect the other end of the spare wire to **R** at the indoor unit or thermostat.

### Thermostat Demand Wiring

The Comfort Alert™ module requires a thermostat demand signal to operate properly. The thermostat demand signal input (labeled **Y** on the module), should always be connected to the compressor contactor coil. **NOTE:** When the coil is energized, the demand signal input is 24

VAC. When the coil is not energized, the demand signal input should be less than 0.5 VAC.

### **NOTES:**

- Factory installed modules have different thermostat demand signal wiring. Always follow manufacturer wiring instructions when replacing the module.
- After the thermostat demand signal is connected, verify that 24 VAC across **Y** & **C** when demand is present.

### Interpreting the Diagnostic LED's

When an abnormal system condition occurs, the Comfort Alert™ module displays the appropriate ALERT and/or TRIP LED will flash a number of times consecutively, pause and then repeat the process. To identify a Flash Code number, count the number of consecutive flashes.

Each time the module powers up, the last ALERT Flash Code that occurred prior to shut down is displayed for one minute. The module will continue to display the LED until the condition returns to normal or if 24 VAC power is removed from the module.

### LED Description

- **POWER LED (Green):** indicates voltage is present at the module's power connection.
- **ALERT LED (Yellow):** communicates an abnormal system condition through a unique flash code. The ALERT LED will flash consecutively, pause and then repeat the process. The number of consecutive flashes, referred to as the Flash Code, correlates to a particular abnormal condition. Detailed descriptions of these ALERT Flash Codes are listed in Table 4 (page 14).
- **TRIP LED (Red):** indicates a demand signal is received from the thermostat, but current to the compressor is not detected by the module. The TRIP LED typically indicates the compressor protector is open or may be missing supply power to the compressor.

The scroll compressor's **R** (run), **C** (common), and **S** (start) wires are routed through the holes in the Comfort Alert™ module marked **R**, **C**, and **S**. **NOTE:** The common wire does not need to be routed through the module for it to operate.

### **2-Speed Outdoor Fan Motor (Select Models)**

If unit uses a 2-speed condenser fan motor, this motor will operate on low speed when in low cooling, and on high speed when in high cooling. A relay within the control area switches the fan motor from low to high speed using the call for high cooling as the trigger.

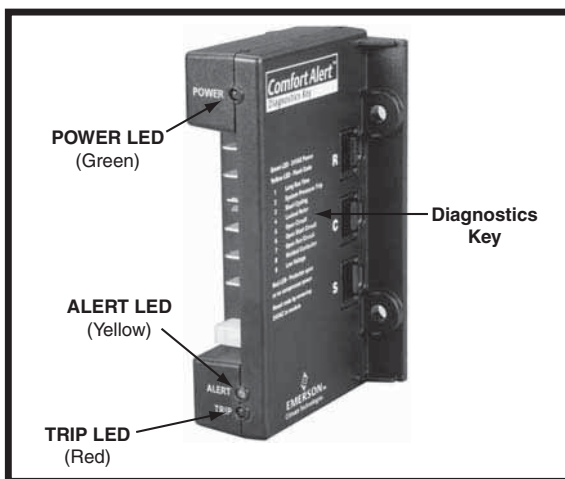

**Figure 3. Comfort Alert™ Diagnostics Module**

## Optional Equipment

Optional equipment requiring connection to the power or control circuits must be wired in strict accordance with current provisions of the NEC (ANSI/NFPA 70), with applicable local codes having jurisdiction, and the installation instructions provided with the equipment. Optional Equipment (low ambient control, hard start kits, etc.) should be installed in strict accordance with the manufacturer's installation instructions.

## Grounding



## WARNING:

**The unit must have an uninterrupted or unbroken electrical ground to minimize personal injury if an electrical fault should occur. This ground may consist of electrical wire or approved conduit when installed in accordance with national or local codes.**

## STARTUP AND ADJUSTMENTS

### Pre-Start Checklist

The following check list should be observed prior to starting the unit.

- √ Is the unit level? Unit should be level or slightly slanted toward the drain for proper condensate drainage.
- √ Is the wiring correct according to the wiring diagram and electrical codes?
- √ Inspect wiring for evidence of open, shorted, and/or improperly wired circuits.
- √ Are all the wiring connections tight? Check the condenser fan to make sure it turns freely.
- √ Is the overcurrent protection properly sized?
- √ Is the thermostat wired correctly? Is it installed in a proper location?
- √ Verify air filters are clean and in place prior to operating the equipment.
- √ Verify the outdoor coil and top of the unit are free from obstructions and debris, and all equipment access/control panels are in place.

### Thermostat

Set the thermostat's system mode to OFF, the fan mode to AUTO, and adjust the temperature setpoint to its highest setting.

### Outdoor Unit

Prior to applying electrical power to the outdoor unit, verify that the unit has been properly and securely grounded, and that power supply connections have been made at both the facility power interface and outdoor unit.

## FUNCTIONAL CHECKOUTS



## CAUTION:

**These units have a crankcase heater factory installed. Wait 24 hours prior to performing a function checkout to allow for heating of the compressor crankcase. Failure to comply may result in damage and could cause premature failure of the system.**

### Cooling

Gradually lower the thermostat temperature setpoint below the actual room temperature and observe that the outdoor unit and indoor blower energize. Feel the air being circulated by the indoor blower and verify that it is cooler than ambient temperature. Listen for any unusual noises. If unusual sounds occur, determine the source of the noise and correct as necessary.

### Heating

If heating equipment (furnace, air handler) is provided with the system, lower the thermostat setpoint temperature to the lowest temperature setting and change the thermostat's function mode to HEAT. The outdoor unit should stop running and the indoor blower will shut off after the preprogrammed delay. Increase the thermostat's setpoint temperature to the maximum setting. Verify the heating equipment and the indoor blower energize after a short period of time. Feel the air being circulated by the indoor blower and verify that it is warmer than ambient temperature. Listen for any unusual noises. If unusual sounds occur, determine the source of the noise and correct as necessary.

**NOTE:** Other heating sources (electric furnace, fossil fuel furnace, air handler with electric heat options, etc.) that interface with the air conditioner should be functionally checked to verify system operation and compatibility. Refer to the installation instructions for this equipment and perform a functional checkout in accordance with the manufacturer's instructions.

### Indoor Blower

1. Turn the fan mode to ON. Verify that the indoor blower is operating and that airflow is not restricted.
2. Set the fan mode back to AUTO. Blower will operate at a decreased speed on continuous fan.

### Short Cycle Protection

1. With the system operating in COOLING mode, record the setpoint temperature setting of the thermostat.
2. Gradually raise the setpoint temperature until the outdoor unit and indoor blower de-energize.
3. Immediately lower the setpoint temperature of the thermostat to its original setting and verify that the indoor blower is energized and that the outdoor unit remains de-energized.
4. After approximately 3 minutes, verify that the outdoor unit energizes and the temperature of the air supplied to the facility is cooler than ambient temperature.

### Optional Equipment

A functional checkout should be performed in accordance with the checkout procedures supplied with the equipment.

### ADJUSTMENT OF REFRIGERANT CHARGE:



## WARNING:

**Split system air conditioners are shipped fully charged with R-410A refrigerant and ready for installation. When a system is installed according to these instructions, no refrigerant charging is required. If repairs make it necessary for evacuation and charging, it should only be done by qualified, trained personnel thoroughly familiar with this equipment. Some local codes require licensed installation/service personnel to service this type of equipment. Under no circumstances should the owner attempt to install and/or service this equipment. Failure to comply with this warning could result in property damage, personal injury, or death.**

### NOTES:

- The unit must be charged while both first and second stages are operating.
- To achieve rated capacity and efficiency the compressor must be exposed to refrigerant for at least 24 hours prior to running and then must be run for a minimum of 12 hours.
- The refrigerant charging charts (Figures 4 - 7, pages 13 - 14) are applicable to matched assemblies of our equipment and at listed airflows for the indoor coil. Assemblies of indoor coils and outdoor units not listed are

not recommended and deviations from rated airflows or non-listed equipment combinations may require modifications to the expansion devices and refrigerant charging procedures for proper and efficient system operation. Factory refrigerant levels are listed in Table 3

*4BF-	System Charge R-410A oz.
024KA	150
036KA	170
048KB	278
060KB	260

**Table 3. Split System Air Conditioner Charge**

### Charging an R-410A unit in AC mode at outdoor temperatures above 65F.

1. With the system operating at steady-state, measure the liquid refrigerant pressure in psig at the service valve.
2. Measure the liquid refrigerant temperature in Fahrenheit at the service valve.
3. For the temperature measured, determine the required liquid refrigerant pressure from the appropriate charging charts in Figures 4 - 7 (pages 13 - 14).
4. If the pressure measured in step 1 is greater than the required liquid refrigerant pressure determined in step 4, then there is too much charge in the system. Remove refrigerant and repeat steps 1 through 3 until the system is correctly charged.
5. If the pressure measured in step 1 is less than the required liquid refrigerant pressure determined in step 4, then there is too little charge in the system. Add refrigerant and repeat steps 1 through 3 until the system is correctly charged.

# Cooling Charging Charts

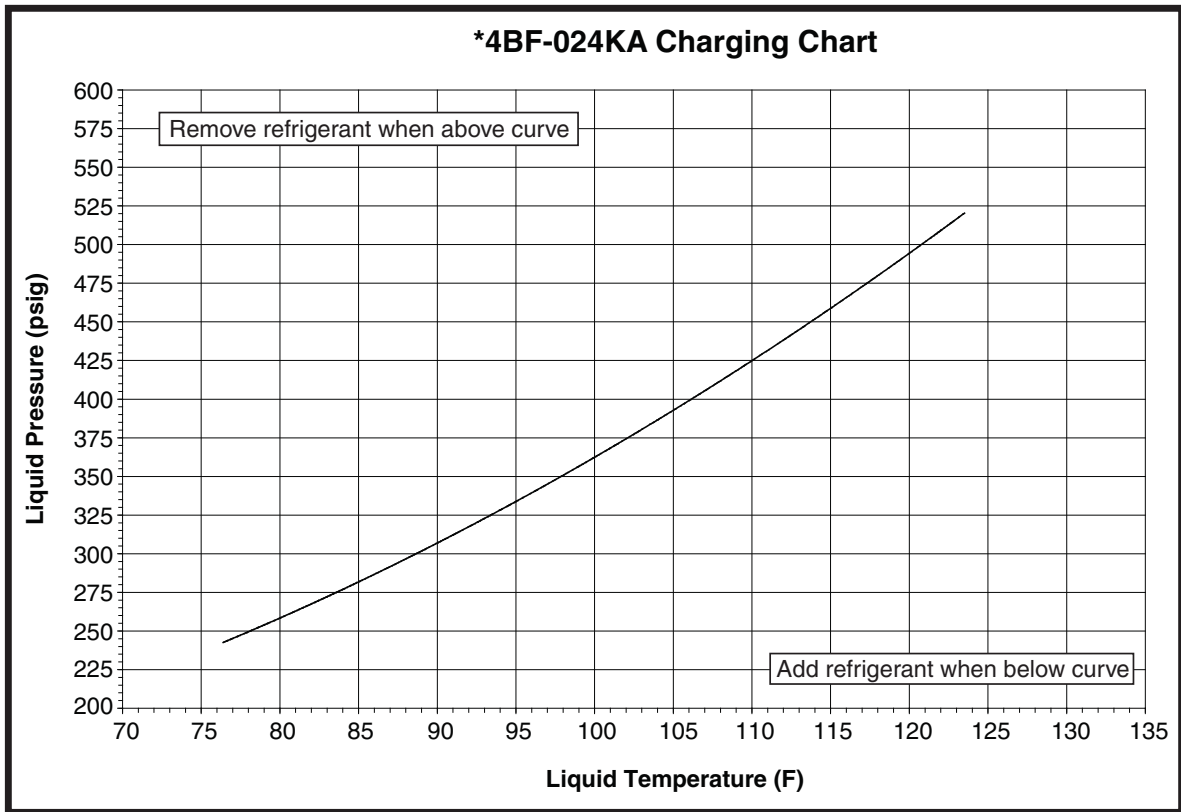

Figure 4. Charging Chart for 2 Ton Units

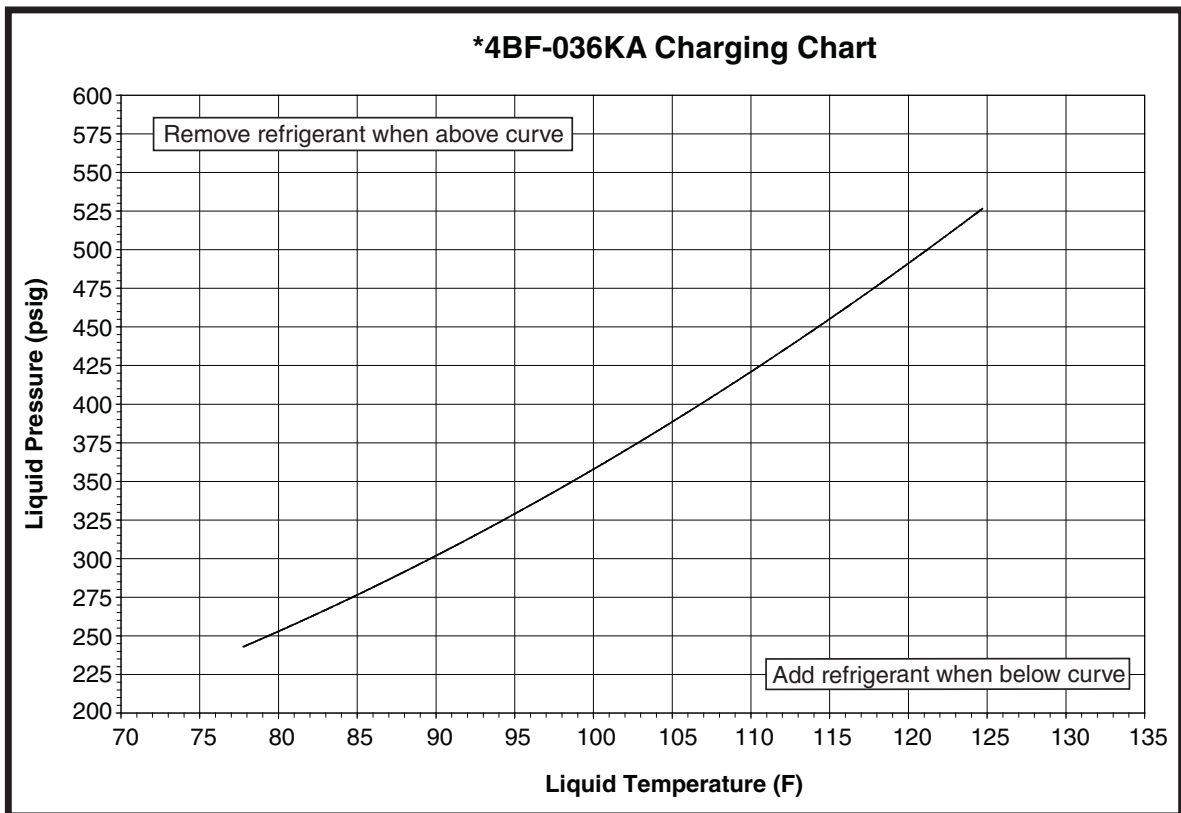
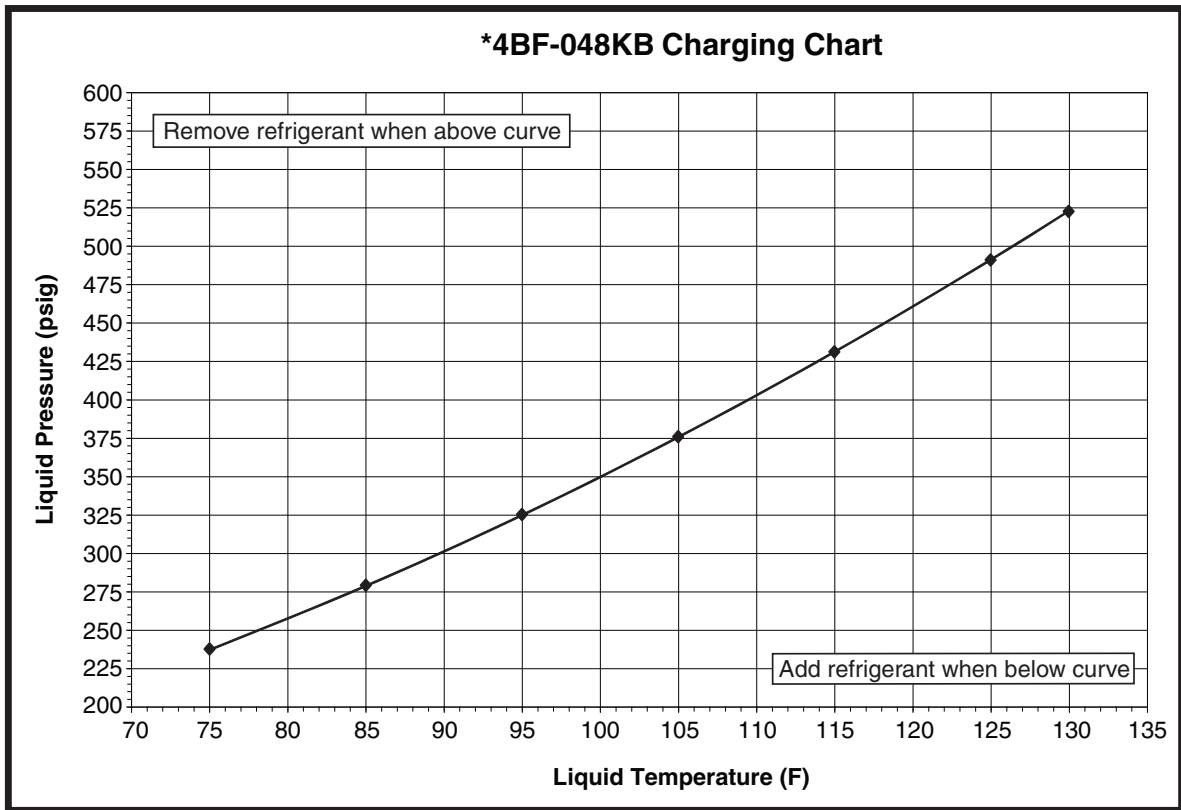
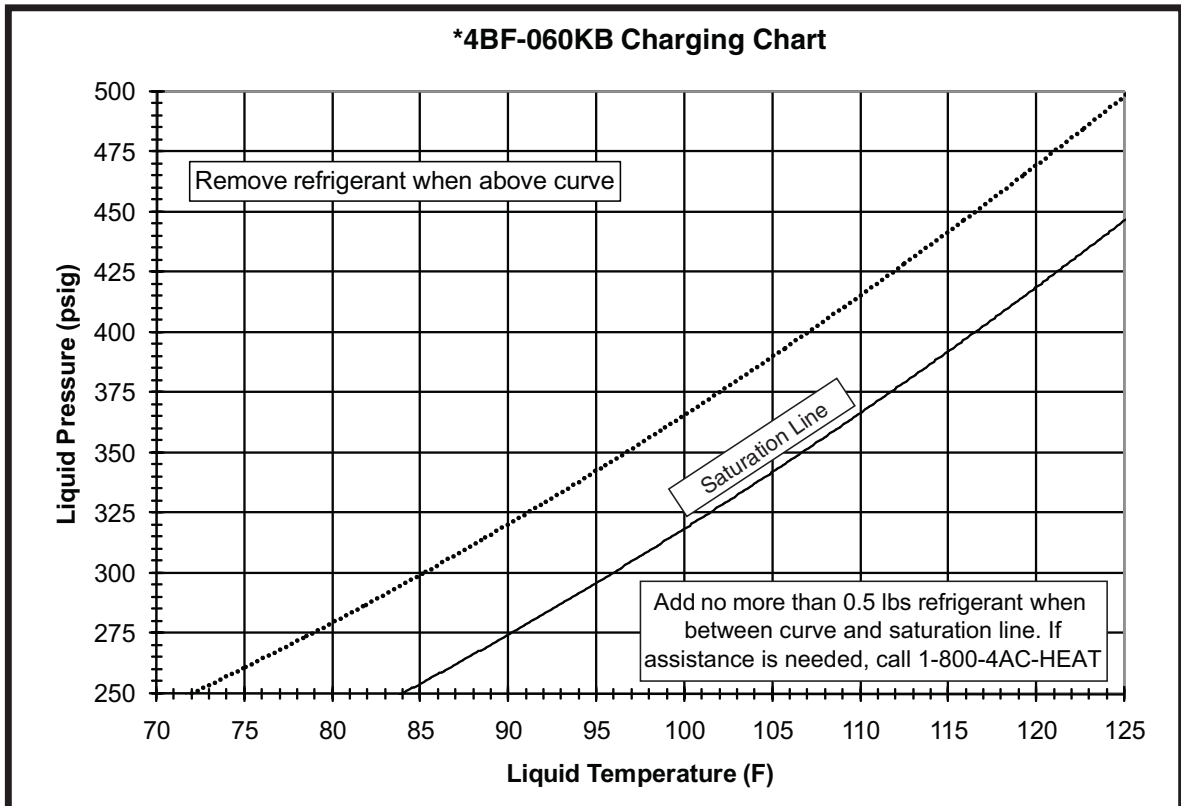

Figure 5. Charging Chart for 3 Ton Units

## Cooling Charging Charts (continued)



**Figure 6. Charging Chart for 4 Ton Units**



**Figure 7. Charging Chart for 5 Ton Units**



## TROUBLESHOOTING

Status LED	Status LED Description	Status LED Troubleshooting Information
Green "POWER"	Module has power	Supply voltage is present at module terminals
Red "TRIP"	Thermostat demand signal Y is present, but compressor is not running	<ul style="list-style-type: none"> <li>• Compressor protector is open</li> <li>• Check for high head pressure</li> <li>• Check compressor supply voltage</li> <li>• Outdoor unit power disconnect is open</li> <li>• Compressor circuit breaker or fuse(s) is open</li> <li>• Broken wire or connector is not making contact</li> <li>• Low pressure switch open if present in system</li> <li>• Compressor contactor has failed open</li> </ul>
Yellow "ALERT" Flash Code 1	<b>Long Run Time</b> Compressor is running extremely long run cycles	<ul style="list-style-type: none"> <li>• Low refrigerant charge</li> <li>• Evaporator blower is not running                             <ul style="list-style-type: none"> <li>— Check blower relay coil and contacts</li> <li>— Check blower motor capacitor</li> <li>— Check blower motor for failure or blockage</li> <li>— Check evaporator blower wiring and connectors</li> <li>— Check indoor blower control board</li> <li>— Check thermostat wiring for open circuit</li> </ul> </li> <li>• Evaporator coil is frozen                             <ul style="list-style-type: none"> <li>— Check for low suction pressure</li> <li>— Check for excessively low thermostat setting</li> <li>— Check evaporator airflow (coil blockages or return airfilter)</li> <li>— Check ductwork or registers for blockage</li> </ul> </li> <li>• Faulty metering device                             <ul style="list-style-type: none"> <li>— Check TXV bulb installation (size, location and contact)</li> <li>— Check if TXV/fixed orifice is stuck closed or defective</li> </ul> </li> <li>• Condenser coil is dirty</li> <li>• Liquid line restriction (filter drier blocked if present in system)</li> <li>• Thermostat is malfunctioning                             <ul style="list-style-type: none"> <li>— Solenoid plug not connected</li> <li>— Y2 not wired at Comfort Alert</li> <li>— Check thermostat sub-base or wiring for short circuit</li> <li>— Check thermostat installation (location, level)</li> </ul> </li> <li>• Comfort Alert failure</li> </ul>
Yellow "ALERT" Flash Code 2	<b>System Pressure Trip</b> - Discharge or suction pressure out of limits or compressor overloaded	<ul style="list-style-type: none"> <li>• High head pressure                             <ul style="list-style-type: none"> <li>— Check high pressure switch if present in system</li> <li>— Check if system is overcharged with refrigerant</li> <li>— Check for non-condensable in system</li> </ul> </li> <li>• Condenser coil poor air circulation (dirty, blocked, damaged)</li> <li>• Condenser fan is not running                             <ul style="list-style-type: none"> <li>— Check fan capacitor</li> <li>— Check fan wiring and connectors</li> <li>— Check fan motor for failure or blockage</li> </ul> </li> <li>• Return air duct has substantial leakage</li> <li>• If low pressure switch present in system, check Flash Code 1 information</li> </ul>

**Table 4. LED Diagnostics**

**TROUBLESHOOTING - CONTINUED**

<b>Status LED</b>	<b>Status LED Description</b>	<b>Status LED Troubleshooting Information</b>
Yellow "ALERT" Flash Code 3	<b>Short Cycling</b> Compressor is running only briefly	<ul style="list-style-type: none"> <li>• Thermostat demand signal is intermittent</li> <li>• Low line voltage (contact utility if voltage at disconnect is low)</li> <li>• Excessive liquid refrigerant in compressor</li> <li>• Compressor bearings are seized</li> </ul>
Yellow "ALERT" Flash Code 4	<b>Locked Rotor</b>	<ul style="list-style-type: none"> <li>• Run capacitor has failed</li> <li>• Low line voltage (contact utility if voltage at disconnect is low)</li> <li>• Check wiring connections</li> <li>• Excessive liquid refrigerant in compressor</li> <li>• Compressor bearings are seized</li> <li>• Measure compressor oil level</li> </ul>
Yellow "ALERT" Flash Code 5	<b>Open Circuit</b>	<ul style="list-style-type: none"> <li>• Outdoor unit power disconnect is open</li> <li>• Compressor circuit breaker or fuse(s) is open</li> <li>• Compressor contactor has failed open                             <ul style="list-style-type: none"> <li>— Check compressor contactor wiring and connectors</li> <li>— Check for compressor contactor failure (burned, pitted or open)</li> <li>— Check wiring and connectors between supply and compressor</li> <li>— Check for low pilot voltage at compressor contactor coil</li> <li>— High pressure switch is open and requires manual reset</li> </ul> </li> <li>• Open circuit in compressor supply wiring or connections</li> <li>• Unusually long compressor protector reset time due to extreme ambient temperature</li> <li>• Compressor windings are damaged                             <ul style="list-style-type: none"> <li>— Check compressor motor winding resistance</li> </ul> </li> </ul>
Yellow "ALERT" Flash Code 6	<b>Open Start Circuit</b> Current only in run circuit	<ul style="list-style-type: none"> <li>• Run capacitor has failed</li> <li>• Open circuit in compressor start wiring or connections                             <ul style="list-style-type: none"> <li>— Check wiring and connectors between supply and the compressor <b>S</b> terminal</li> </ul> </li> <li>• Compressor start winding is damaged                             <ul style="list-style-type: none"> <li>— Check compressor motor winding resistance</li> </ul> </li> </ul>
Yellow "ALERT" Flash Code 7	<b>Open run circuit</b> Current only in start circuit	<ul style="list-style-type: none"> <li>• Open circuit in compressor run wiring or connections                             <ul style="list-style-type: none"> <li>— Check wiring and connectors between supply and the compressor <b>R</b> terminal</li> </ul> </li> <li>• Compressor run winding is damaged                             <ul style="list-style-type: none"> <li>— Check compressor motor winding resistance</li> </ul> </li> </ul>
Yellow "ALERT" Flash Code 8	<b>Welded Contactor</b> Compressor always runs	<ul style="list-style-type: none"> <li>• Compressor contactor has failed closed</li> <li>• Thermostat demand signal not connected to module</li> </ul>
Yellow "ALERT" Flash Code 9	<b>Low Voltage</b> Control circuit < 17VAC	<ul style="list-style-type: none"> <li>• Control circuit transformer is overloaded</li> <li>• Low line voltage (contact utility if voltage at disconnect is low)</li> <li>• Check wiring connections</li> </ul>
<p>* Flash code number corresponds to a number of LED flashes, followed by a pause and then repeated. Trip and alert LED's flashing at same time means control circuit voltage is too low for operation.</p>		

**Table 4. LED Diagnostics - Continued**

**TROUBLESHOOTING - CONTINUED**

<b>Miswired Module Indication</b>	<b>Recommended Troubleshooting Action</b>
Green LED is not on, module does not power up	<ul style="list-style-type: none"> <li>• Determine if both <b>R</b> &amp; <b>C</b> module terminals are connected.</li> <li>• Verify voltage is present at module's <b>R</b> &amp; <b>C</b> terminals.</li> </ul>
Green LED intermittent, module powers up only when compressor runs	<ul style="list-style-type: none"> <li>• Determine if <b>R</b> &amp; <b>Y</b> terminals are wired in reverse.</li> <li>• Verify modules <b>R</b> and <b>C</b> terminals have a constant source.</li> </ul>
Trip LED is on, but system and compressor check OK	<ul style="list-style-type: none"> <li>• Verify <b>Y</b> terminal is connected to 24VAC at contactor coil.</li> <li>• Verify voltage at contactor coil falls below 0.5VAC when off.</li> <li>• Verify 24VAC is present across <b>Y</b> &amp; <b>C</b> when thermostat demand signal is present. If not, <b>R</b> &amp; <b>C</b> are reversed wired.</li> </ul>
TRIP LED and ALERT LED flashing together	<ul style="list-style-type: none"> <li>• Verify <b>R</b> and <b>C</b> terminals are supplied with 19 - 28VAC.</li> </ul>
ALERT Flash CODE 3 displayed incorrectly (Compressor short cycling)	<ul style="list-style-type: none"> <li>• Verify <b>Y</b> terminal is connected to 24VAC at contactor coil.</li> <li>• Verify voltage at contactor coil falls below 0.5VAC when off.</li> </ul>
ALERT Flash Code 5, 6, or 7 displayed incorrectly (Open Circuit, Open Start Circuit or Open Run Circuit)	<ul style="list-style-type: none"> <li>• Verify the compressor run and start wires are routed through the module's current sensing holes.</li> <li>• Verify the <b>Y</b> terminal is connected to 24VAC at contactor coil.</li> <li>• Verify voltage at contactor coil falls below 0.5VAC when off.</li> </ul>
ALERT Flash Code 6 (Open Start Circuit) displayed for Code 7 (Open Run Circuit) or vice-versa	<ul style="list-style-type: none"> <li>• Verify the compressor run and start wires are routed through the correct module sensing holes.</li> </ul>
ALERT Flash Code 8 displayed incorrectly (Welded Contactor)	<ul style="list-style-type: none"> <li>• Determine if module's <b>Y</b> terminal is connected.</li> <li>• Verify <b>Y</b> terminal is connected to 24VAC at contactor coil.</li> <li>• Verify 24VAC is present across <b>Y</b> &amp; <b>C</b> when thermostat demand signal is present. If not, <b>R</b> and <b>C</b> are reversed wired.</li> <li>• Verify voltage at contactor coil falls below 0.5VAC when off.</li> <li>• Review Thermostat Demand Wiring (page 10) for <b>Y</b> &amp; <b>C</b> wiring.</li> </ul>

**Table 5. Module Wiring Troubleshooting**





**INSTALLER: PLEASE LEAVE THESE  
INSTALLATION INSTRUCTIONS WITH  
THE HOMEOWNER.**



**NORDYNE**  
COMPLETE COMFORT. GENUINE VALUE.

O'Fallon, MO

¢709129; α

7091290

**7091290**(Replaces 7090240)  
Specifications and illustrations subject to change  
without notice or incurring obligations.  
Printed in U.S.A. (11/09)